



CU Aerospace (CUA) has developed a family of satellite propulsion technologies to offer versatility to the CubeSat community. The Fiber-fed Pulsed Plasma Thruster (FPPT) self-contained system uses PTFE (Teflon®) fiber as propellant (no liquid or gaseous propellant requiring pressure vessels or valving). FPPT provides a CubeSat with significant orbit altitude change, collision avoidance, and ultimately deorbit capabilities. In a 1.7U form factor, FPPT can provide a peak total impulse of 29,000 N-s, a peak continuous thrust of 0.275 mN at 55 W input power, and a maximum specific impulse of 3,870 seconds. The design incorporates a modularized 32 J energy storage unit (ESU) to achieve a balance between performance and propellant volume. Steady operation at 0.5Hz has been demonstrated with 3Hz capability in shorter duration burns. The FPPT has a unique gimbal-less thrust vectoring capability allowing reaction wheel desaturation and attitude control outside Earth’s magnetic field. An FPPT flight unit was qualified and integrated into CUA’s NASA-funded Dual Propulsion Experiment (“DUPLEX”) 6U CubeSat, which has been delivered and is manifested for launch in Q3/Q4 of 2025. Subsequent DUPLEX flight operations will achieve TRL 8/9 for the FPPT technology. Thrust vectoring of ±5 in the pitch and yaw axes has been measured on a laboratory FPPT system and will be demonstrated on the DUPLEX mission.



OPERATION AND TYPICAL PERFORMANCE

FPPT fires on demand without warmup. It mechanically feeds PTFE propellant fiber from a non-rotating spool through the anode, utilizing a pulsed discharge to electromagnetically accelerate fuel to provide thrust. Power, thrust, mass flow rate, and resultant specific impulse levels are user-selectable by adjusting propellant feed rate, pulse rate, and bank voltage.

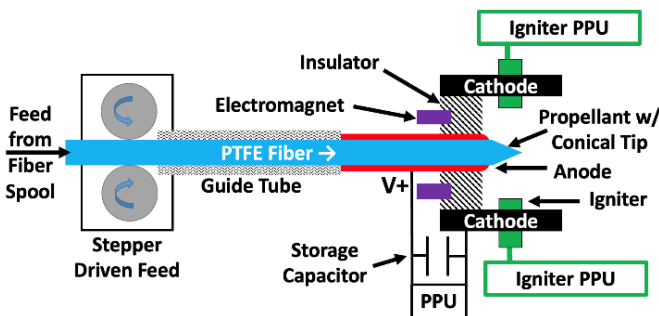

System Information		
System Lifetime	> 10 ⁸ pulses	
System Temperature Range [°C]	- 40 to +75	
Nominal Pulse Energy [J]	19	
Propulsion System Volume	1.7U	
Pulse Rate [Hz]	0.64	1.6
Nominal Power to PPU [W]	16	55
Nominal Mass Flow Rate [mg/s]	0.00179	0.00448
Nominal Thrust [mN]	0.07	0.28
Minimum Impulse Bit [μN-s]	109	
Specific Impulse [s]	3,870	
Total Impulse [N-s]	29,000	
Propellant Mass [kg]	0.78	
Total propulsion wet mass [kg]	3.03	
Spacecraft ΔV [m/s], for 10.5 kg S/C wet mass	2,920	
TRL	6	

FIBER-FED PULSED PLASMA THRUSTER (FPPT)

BASELINE 1.7U FPPT SYSTEM INTERFACE

- 12V power interface
- RS422 or TTL-level UART comms protocols available
- Mounting interface
 - Designed for typical CubeSat structure with external enclosure
 - Adaptable to customer requirements
- 21.7 x 9.0 x 8.65 cm³ envelope
- Total mass of 3.03 kg

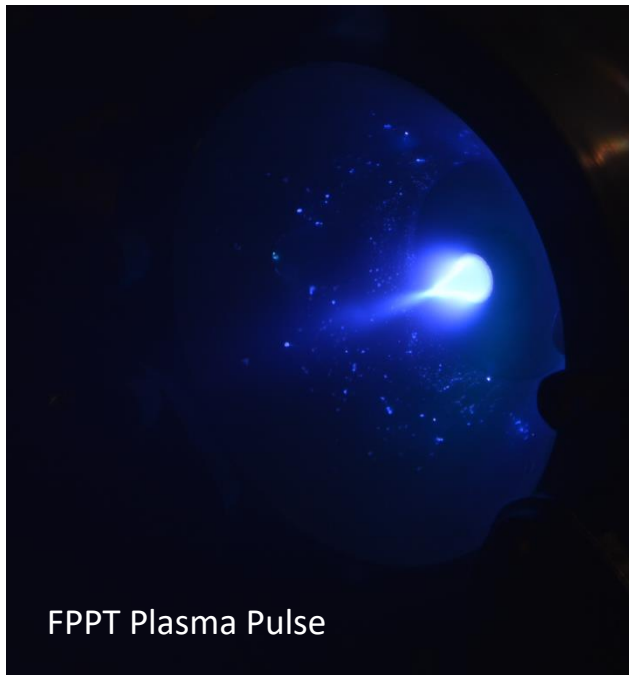
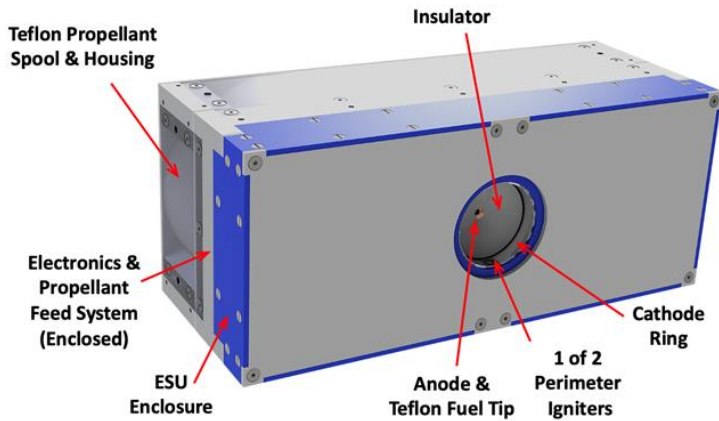

FPPT VARIANT ENVELOPES

Quick Turn (QT) PPTs

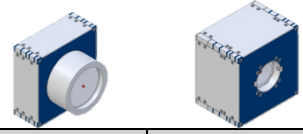

PARAMETER	QT-PPT (Disc)	QT-PPT (FIBER)
Volume	550 cm ³	670 cm ³
Nominal Power Draw	20 (2 Hz)	20 (2 Hz)
Capacitor Bank Energy	7.4 J	7.4 J
Specific impulse	700 s	1,575 s
Mass per Pulse	0.010 mg	0.0023 mg
Thrust (@ Pulse Rate)	0.14 mN (2 Hz)	0.07 mN (2 Hz)
Total impulse	1,100 N-s	2,700 N-s
Propellant Mass	160 g	170 g
Dry Mass	630 g	750 g
Propulsion Wet Mass	790 g	920 g
Thrust Vectoring	No	Yes (±5°)
Delta-V capability	280 m/s (4 kg S/C Wet Mass)	450 m/s (6 kg S/C Wet Mass)
TRL	5	5

FPPT-ESPA

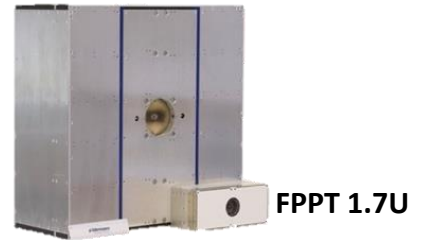

PARAMETER	FPPT-ESPA
Volume	52,500 cm ³
Nominal Power Draw	185 (2 Hz)
Capacitor Bank Energy	75 J
Specific impulse	3,300 s
Mass per Pulse	0.019 mg
Thrust (@ Pulse Rate)	1.2 mN (@ 2 Hz)
Total impulse	500,000 N-s
Propellant Mass	35,000 g
Dry Mass	20,000 g
Prop. Sys. Wet Mass	55,000 g
Thrust Vectoring	Yes (±5°)
Delta-V capability	4,880 m/s (250 kg S/C Wet Mass)
TRL	5